

Backed Bench Plan

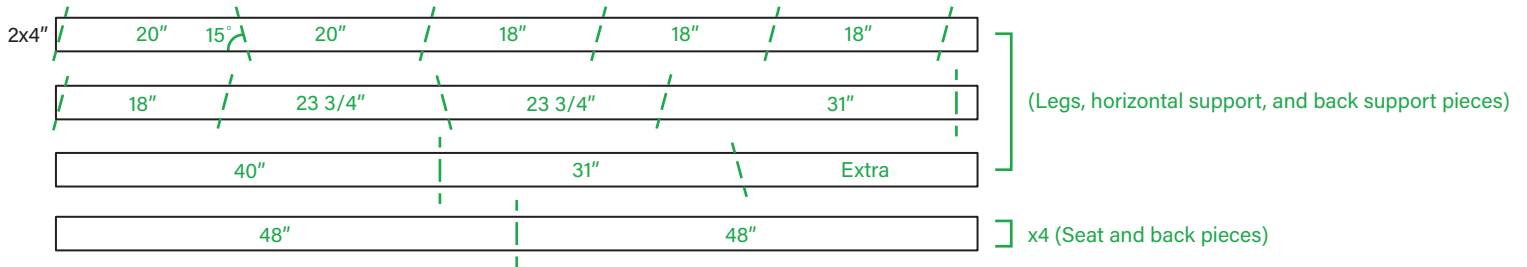

MATERIALS AND TOOLS:

- (7) 2x4" eight-foot pieces of lumber
- Saw, drill, 2 1/2" decking screws
- All angled cuts are 15 degrees
- To create 15 degree cut - use speed square or measure 15/16" from edge



BUILD INSTRUCTIONS:

- Start by assembling the legs, with two screws per connection
- Make sure all edges are flush when connecting pieces
- Attach the back support pieces so that the two sides mirror each other
- Connect the horizontal support piece, making sure that it goes in square to both sides
- Attach the seat pieces and then the back pieces, leaving an even gap between each piece

1

Line up one corner at a time - making sure all edges are flush

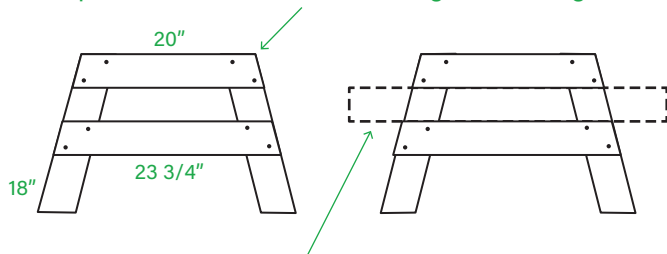

Use extra 2x4" as a spacer between 20" and 23 3/4" pieces

2

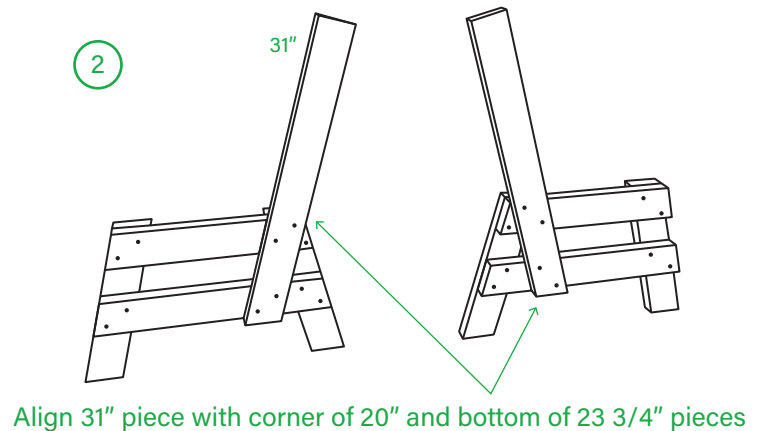

Align 31" piece with corner of 20" and bottom of 23 3/4" pieces

3

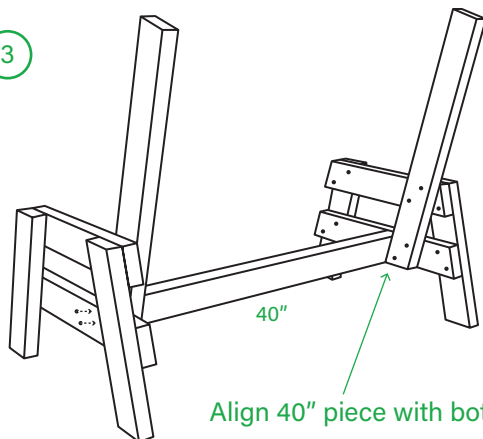

Align 40" piece with bottom of back support Overhang should be the same on both sides

4

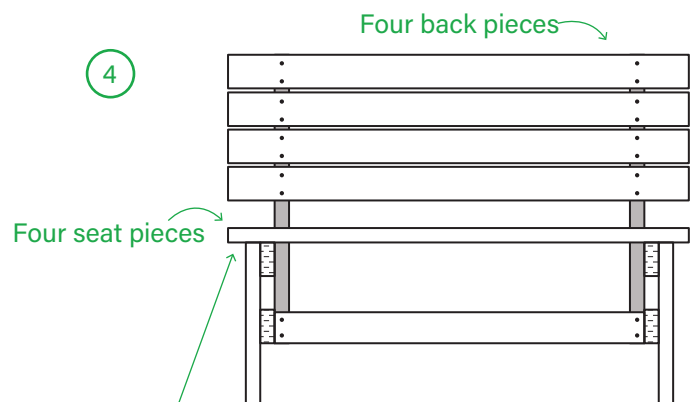

Four seat pieces

Four back pieces